

ESC. 1:2	Torneira Lavatório Alto Célula Pilha 6V Ou 220V Cilíndrica							
Desenhou 20/06/2020			SN001A					
Rev: 1 24/03/2022								

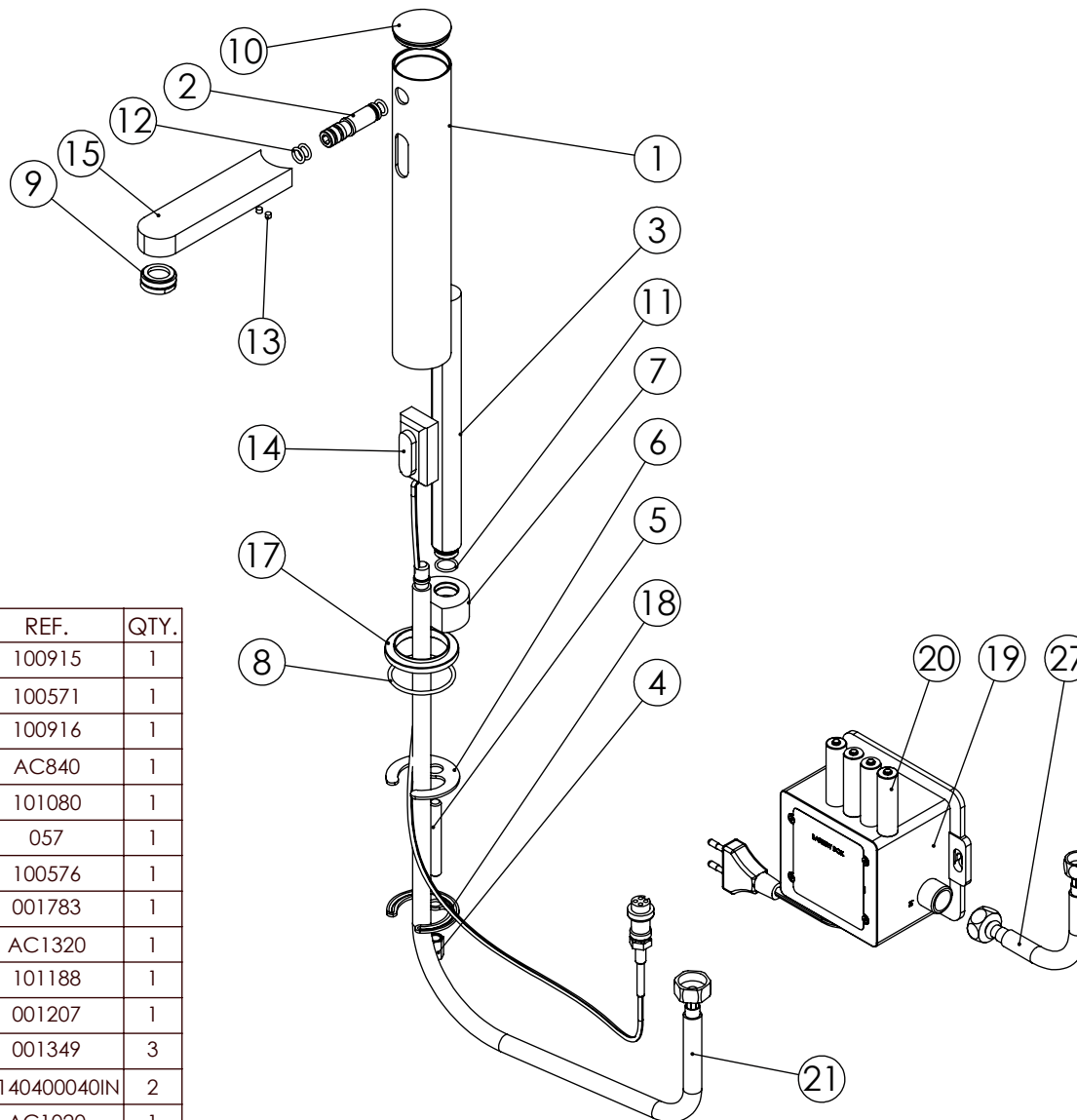

ITEM NO.	DESCRIPTION	REF.	QTY.
1	Corpo Torneira Lavatório Alta Célula 1 Água	100915	1
2	Embolo da Bica Célula	100571	1
3	Condutor água Lavatório Alto Célula Longo	100916	1
4	Fêmea Fixação M8	AC840	1
5	Perno Fixação Monoblocos 60mm	101080	1
6	Anilha Ferradura	057	1
7	Distribuidor Torneira Lavatório Célula	100576	1
8	Orings 41.00x2.50 NBR 70	001783	1
9	Perlator 24x1 Min. Slim	AC1320	1
10	Tampa Torneira Célula Lavatório 1 Água	101188	1
11	Orings 12.50x1.60 NBR 70	001207	1
12	Orings 8.00x1.90 NBR 70	001349	3
13	Perno Umbrako Din 914 M4-4 Inox A-2	09140400040IN	2
14	Sensor Célula	AC1020	1
15	Bica Lavatório Alto Bracara 120mm	100501	1
16	Ligação 350mm G1-2 M10X1	AC851	1
17	Páter das Células 1 Água	100918	1
18	Ferradura Chapa	0070C840	1
19	Válvula+Transformador	AC1030	1
20	Bateria Lithium LR6 1,5V	AC1380	4
21	Ligação 350mm G1-2 M10 180°	AC851	1

ESC.
1:5

Torneira Lavatório Alto Célula Pilha
6V Ou 220V Cilíndrica

Desenhou
20/06/2020
Rev: 1
24/03/2022

ASMTAPS
WATER SOUL

SN001A

Service:

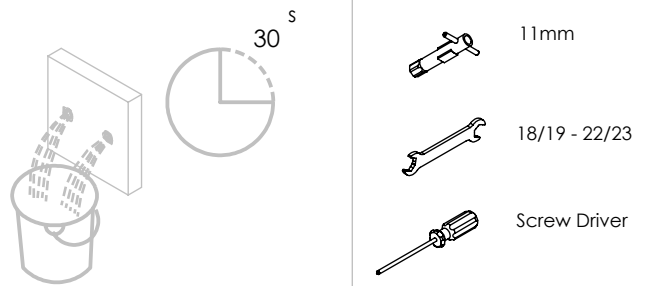

Washbasin Mixer Installation Manual

2°

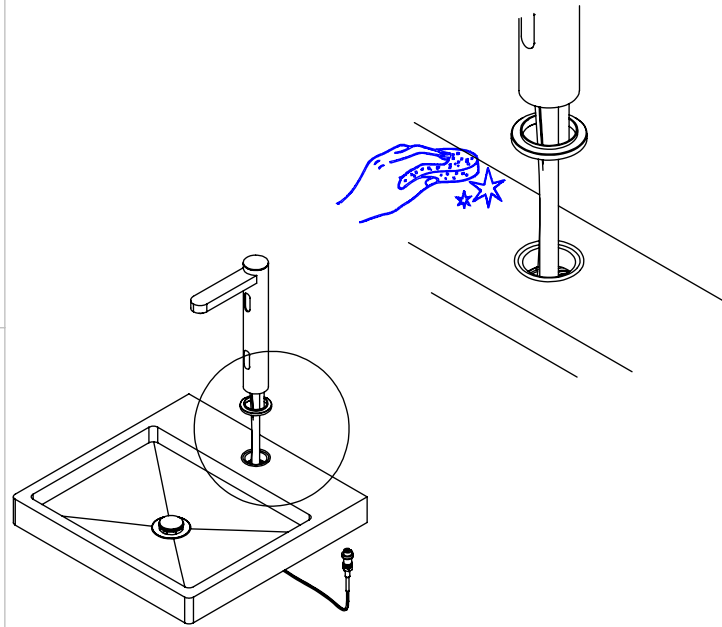

3°

Fixed:

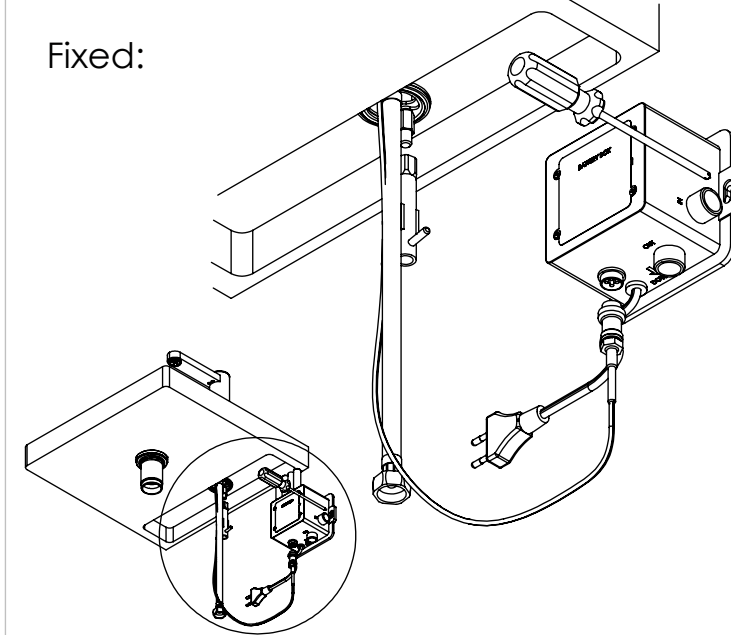

4°

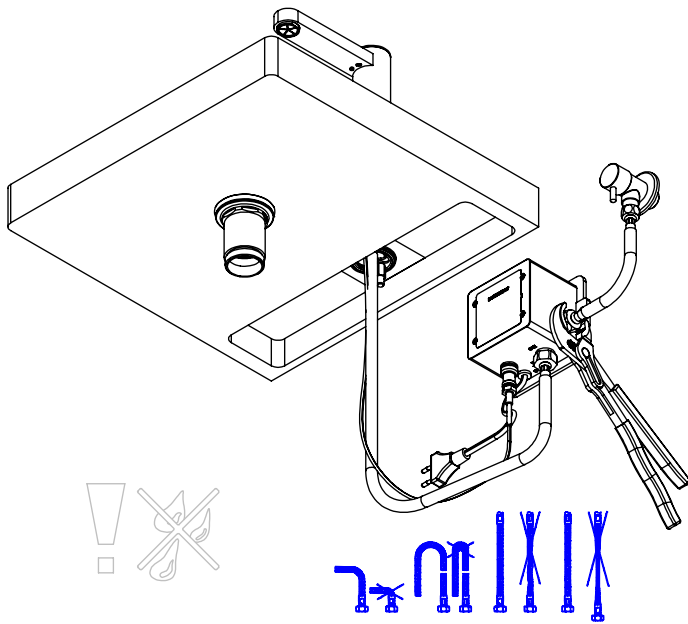

5°

Maintenance:

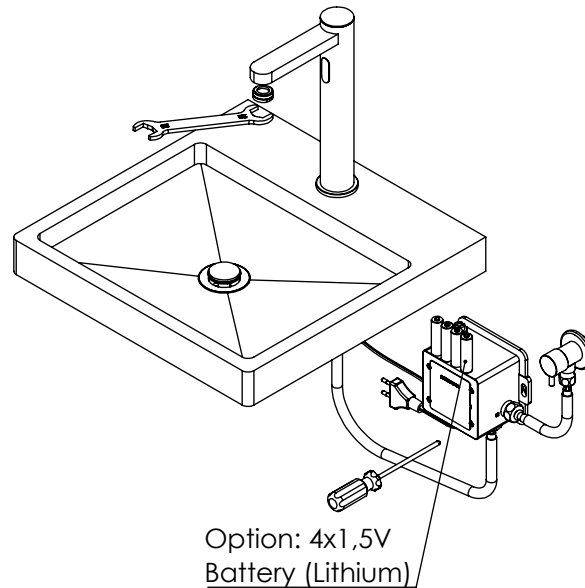

Technical specifications

Voltage supply	DC6V
Working pressure	1 - 7 bar
Pressure resistance closed (1 min)	35 bar
Life test	500.000 cycles
Max. Hot water	75°C
Flow rate (RhA)	10.8 l/min
Sensor activation time	<1 s
Protection against intrusion (control box)	IP 65
Protection against intrusion (sensor)	IP 67
Sensor detection distance	≤ 35 cm
Power consumption (standby)	< 0,2mW
Power consumption (flushing)	< 3W
Water Saving Function	Auto off adjustable up to 1 min
Thread	G 1/2 - 14
Battery type (included)	4 X AA 1.5V
Sensor detection angle	15 deg (conical)