

# CROSS070C

MONOC. EMBUTIR LAVAT. PAREDE  
ESPELHOS SEPARADOS CROSSLINE



ASM TAPS®

WATER SOUL

**EN** CONCEALED WASHBASIN MIXER  
CROSSLINE

**FR** MITIGEUR LAVABO ENCASTRÉE  
CROSSLINE

**ES** MONOMANDO LAVABO EMPOTRAR  
CROSSLINE

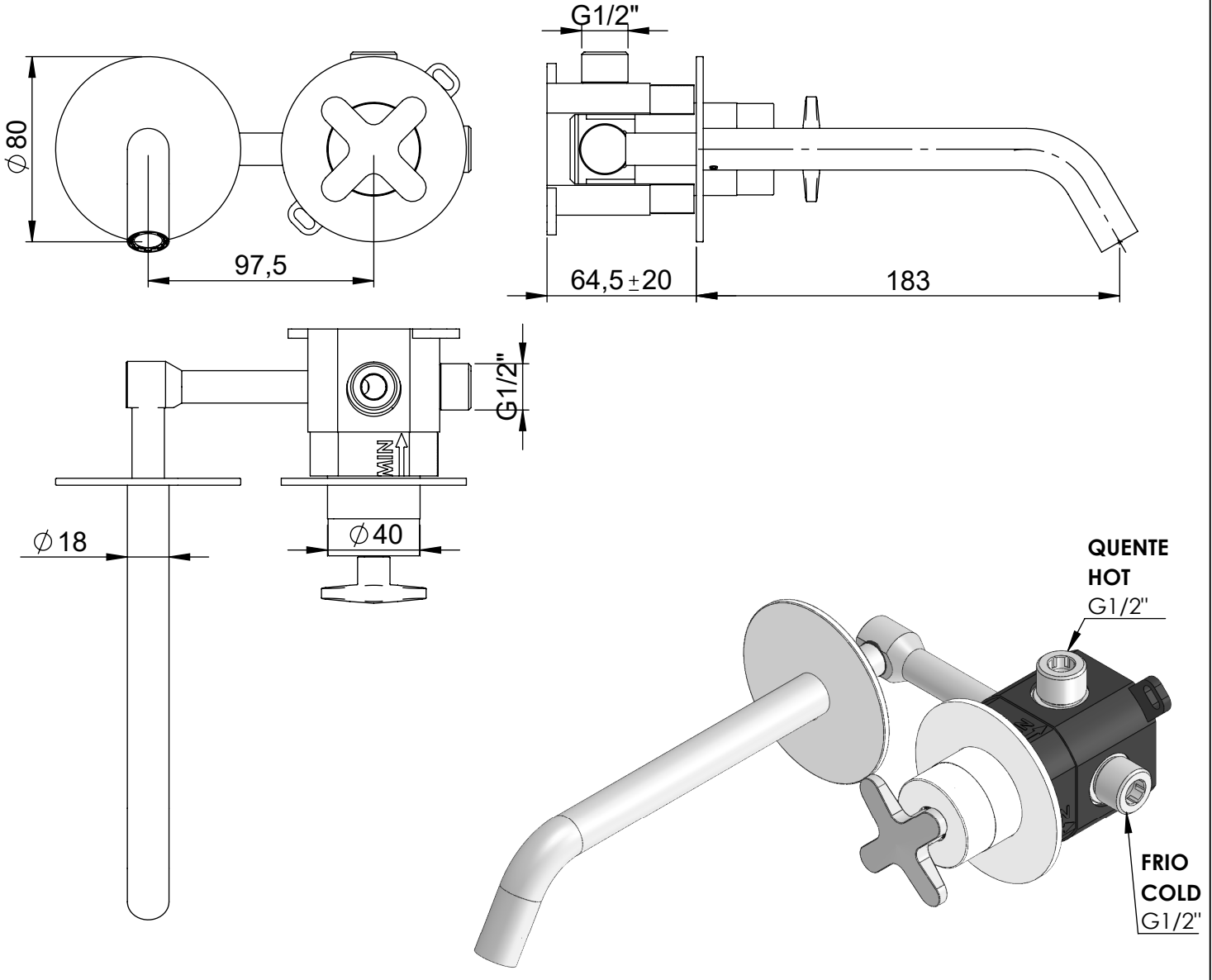

QUENTE  
HOT  
G1/2"

FRIO  
COLD  
G1/2"

CROSS070C Rev. B 11/05/2026

## CARACTERÍSTICAS TÉCNICAS

PRESSÃO RECOMENDADA: RECOMMENDED PRESSURE:	3 - 4 BAR
TEMPERATURA RECOMENDADA: RECOMMENDED TEMPERATURE:	15°C - 65°C
MATERIAIS: MATERIALS:	Latão
TEMPERATURA MÁXIMA: MAXIMUM TEMPERATURE:	70°C
CAUDAL MÁXIMO A 3 BAR: MAXIMUM FLOW AT 3 BAR:	5L/MIN
LIGAÇÃO DE ENTRADA: INPUT CONNECTION:	G1/2"
LIGAÇÃO DE SÉIDA: OUTPUT CONNECTION:	G1/2"
PESO (KG): WEIGHT (KG):	-
DIMENSÕES EMBALAGEM (MM): SIZE PACKAGING (MM):	274x162x102

## ACABAMENTOS

CR - CROMADO   CHROME   CHROME   CROMO
PR - PRETO MATE   BLACK MATT   NOIR MAT   NEGRO MATE
BR - BRANCO MATE   WHITE MATT   BLANC MAT   BLANCO MATE
ST - SATINOX   SATINOX   SATINOX   SATINOX
AT - ANTRACITE   ANTHRACITE   ANTHRACITE   ANTRACITA
GM - GUNMETAL   GUNMETAL   GUNMETAL   GUNMETAL
GMM - GUNMETAL MATE   GUNMETAL MATT   GUNMETAL MAT   GUNMETAL MATE
OR - DOURADO   GOLD   DORÉ   DORADO
ORM - DOURADO MATE   GOLD MATT   DORÉ MAT   DORADO MATE
CB - COBRE   COPPER   CUIVRE   COBRE
CBM - COBRE MAT   COPPER MAT   CUIVRE MAT   COBRE MATE

## TECNOLOGIA

- AC1340 - Cartucho Progressivo Ø35  
AC1340 - Progressive Cartridge Ø35
- Embutido a parede  
Built-in to wall
- Perlator Embutido  
Built-in Aerator

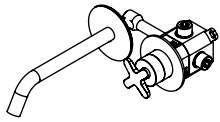

# CROSS070C

MONOC. EMBUTIR LAVAT. PAREDE  
ESPELHOS SEPARADOS  
CROSSLINE



ASM TAPS®

WATER SOUL

## LISTA DE COMPONENTES

CROSS070C Rev.B 11/05/2026

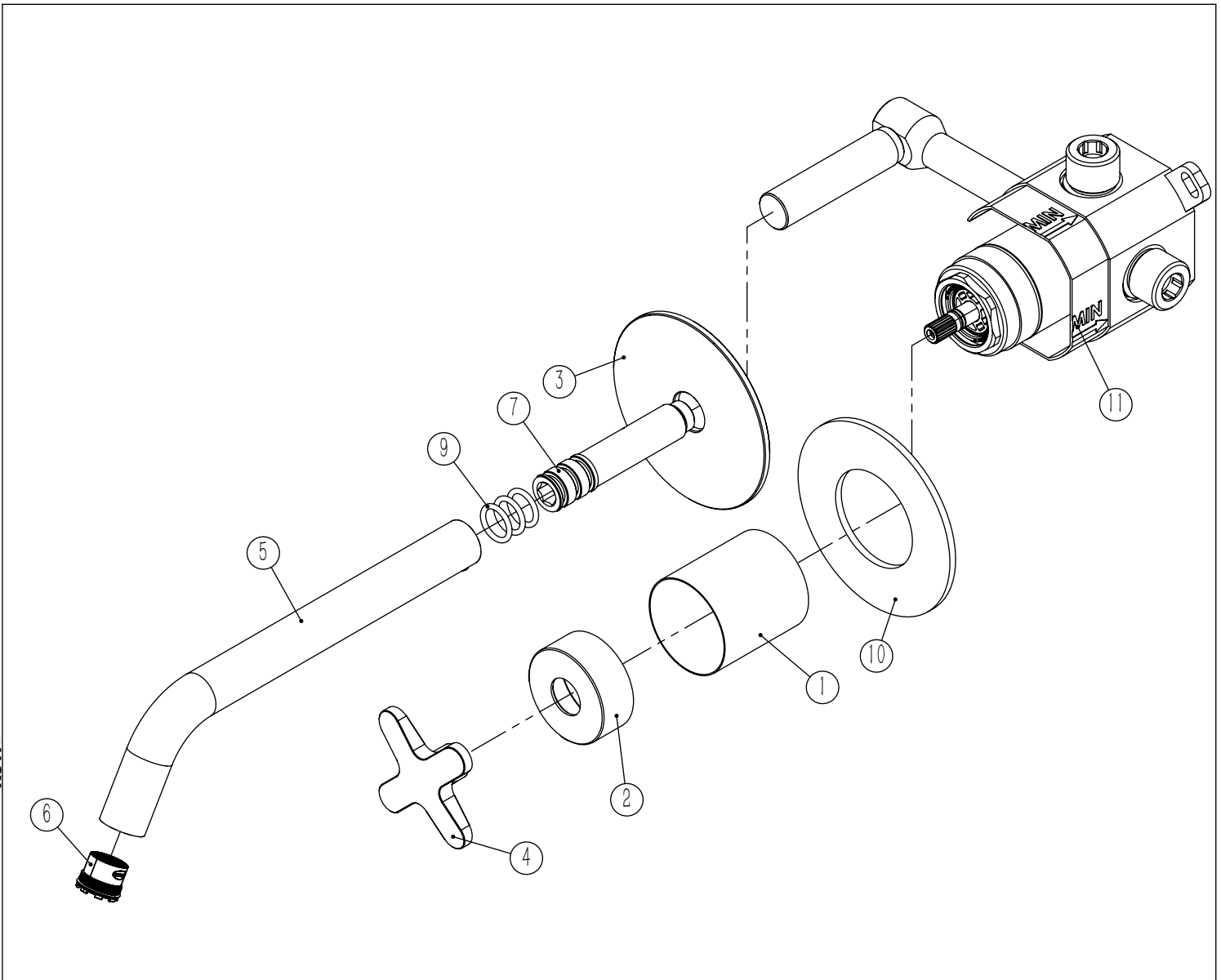

Nº	DESCRIPTION	REF.	QT.
1	COPO EXTERIOR EMBUTIDOS CRUZETA	101568	1
2	Porca Campanula Cartucho Progressivo	100860	1
3	PATER BICA PAREDE CILÍNDRICA	101425	1
4	MANÍPULO CROSSLINE	AC2360	1
5	Bica Parede Slim	100410	1
6	Perlator 16,5x1 Cilíndrico/Quadra	AC850A	1
7	PONTEIRA BICA PAREDE SLIMASM	100038	1
8	Perno Umbrako Din 914 M4-4 Inox A-2	09140400040IN	2
9	Orings 10.00x2.00 NBR 70	001367	4
10	ESPELHO 1 VIA CILÍNDRICO	100274	1
11	BOX MONOC. EMBUTIR LAV./SANITA BIDÉ PROGRESSIVO ESP. SEPARADOS	INT127	1

# ! SERVICE



# CROSS070C

MONOC. EMBUTIR LAVAT. PAREDE  
ESPELHOS SEPARADOS  
CROSSLINE



A S M T A P S

W A T E R S O U L

## INSTALLATION MANUAL

### 1 CONECTION

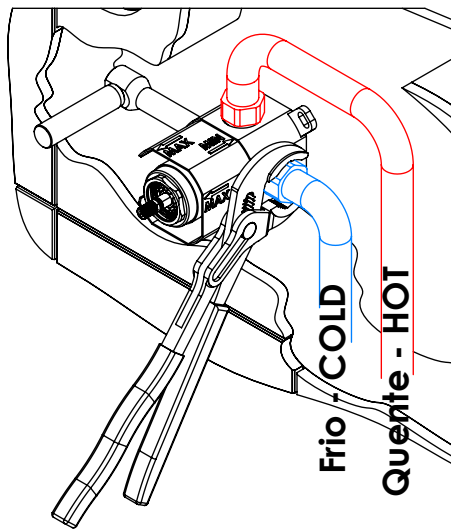

### 2 FIXED

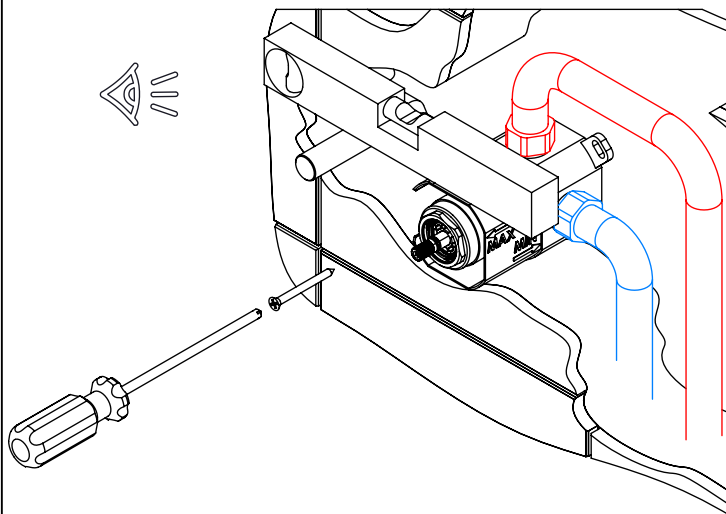

### 3 REMOVE PROTECTION

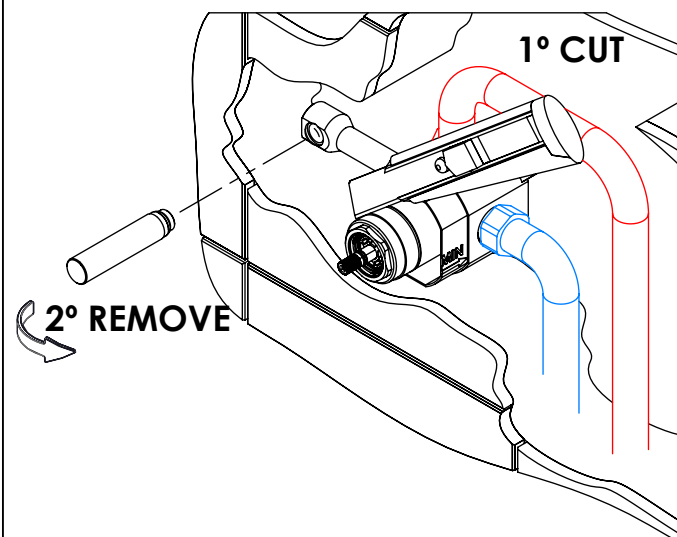

### 4 FIX IT

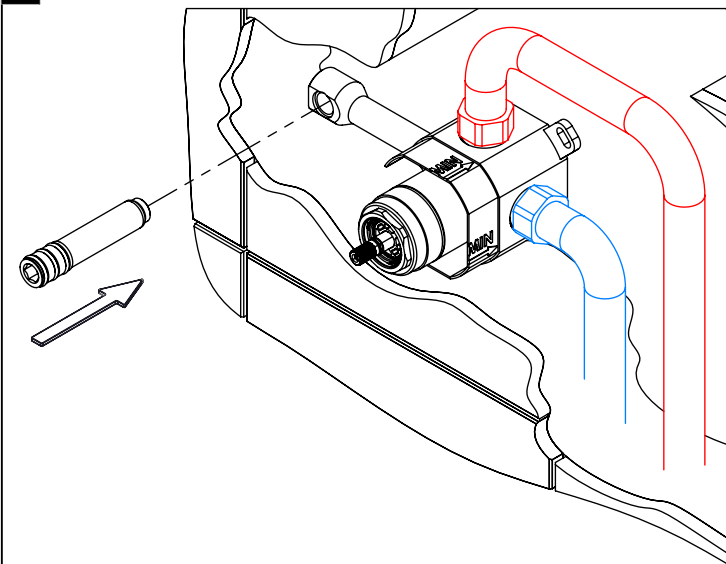

### 5 FIX IT

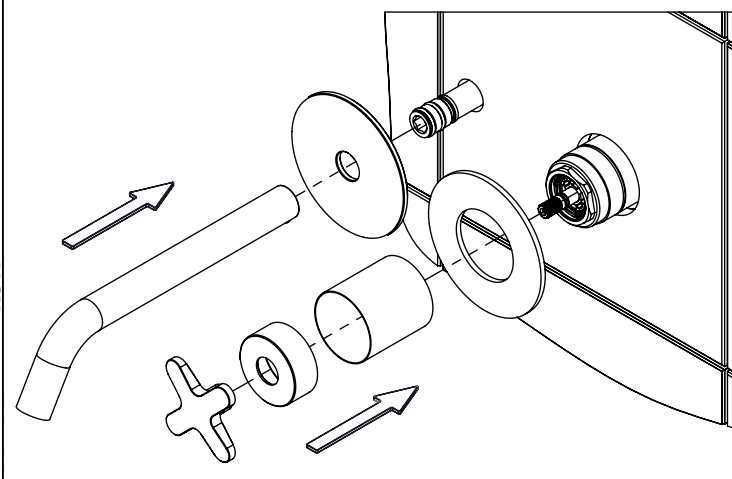

### 6 MAINTENANCE

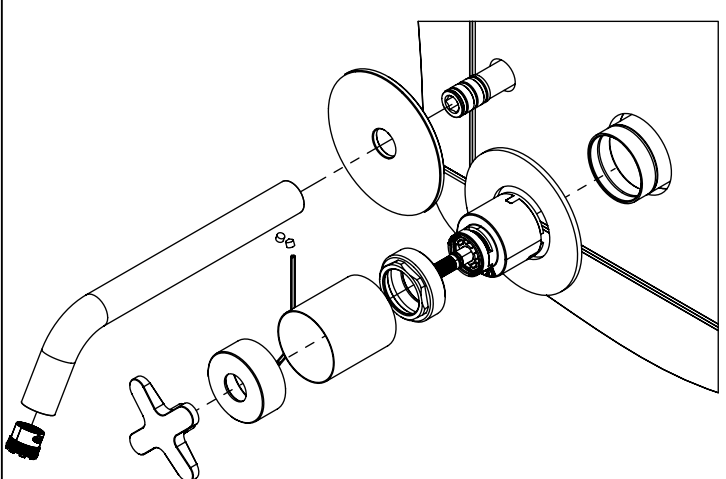

CROSS070C Rev. B 11/05/2026