

CROSS090

MONOCOMANDO EMBUTIR DUCHE 1
VIA CROSSLINE



ASM TAPS®

WATER SOUL

LISTA DE COMPONENTES

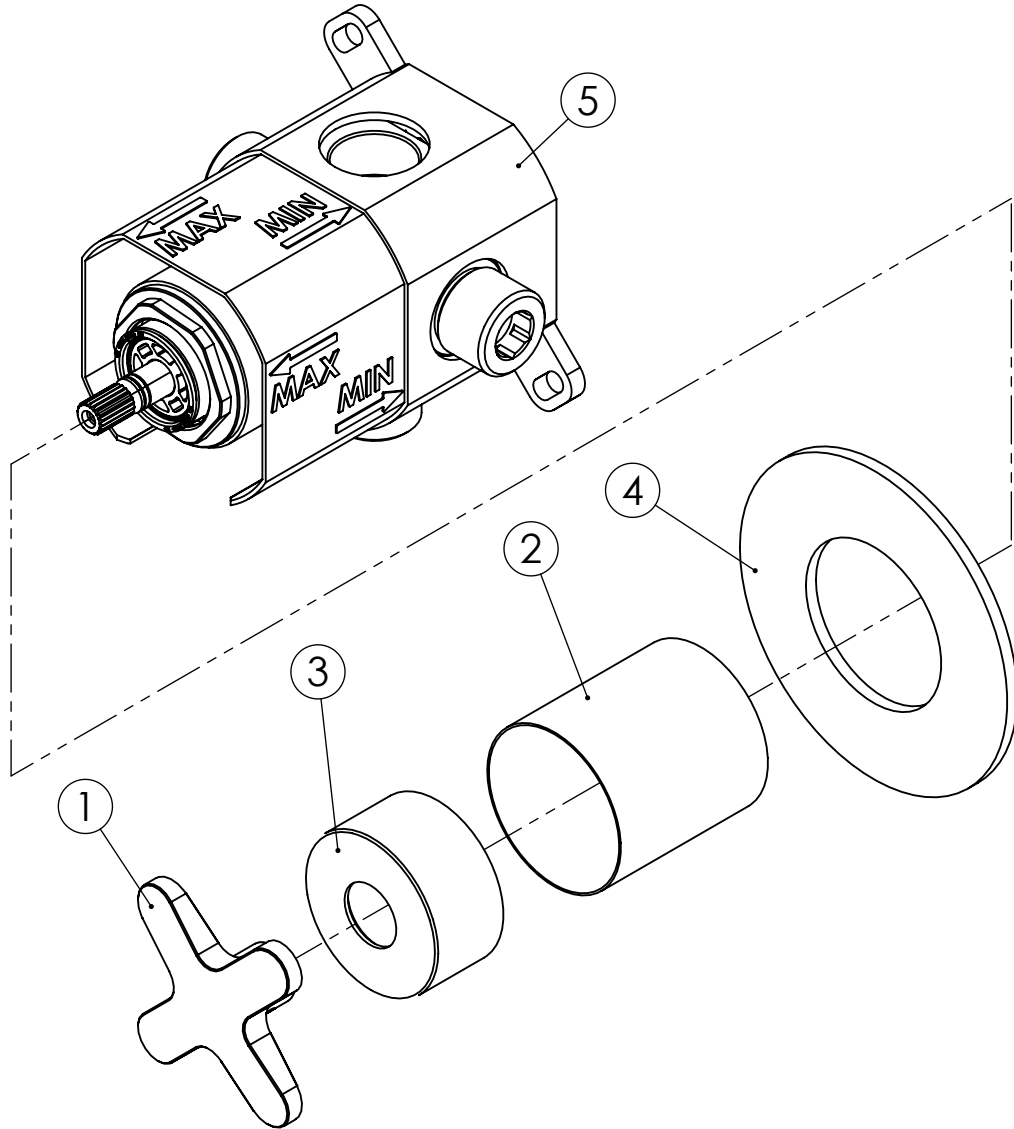

Nº	DESCRIPTION	REF.	QT.
1	MANÍPULO CROSSLINE	AC2360	1
2	COPO EXTERIOR EMBUTIDOS CRUZETA	101568	1
3	Porca Campanula Cartucho Distr. Cruzeta	100861	1
4	ESPELHO 1 VIA CILÍNDRICO	100274	1
5	BOX MONOC. EMBUTIR LAVATÓRIO SEP./ DUCHE 1 VIA PROGRESIVO	INT129	1

! SERVICE



CROSS090

MONOCOMANDO EMBUTIR DUCHE 1 VIA CROSSLINE



A S M T A P S ®

W A T E R S O U L

INSTALLATION MANUAL

1 CONECTION

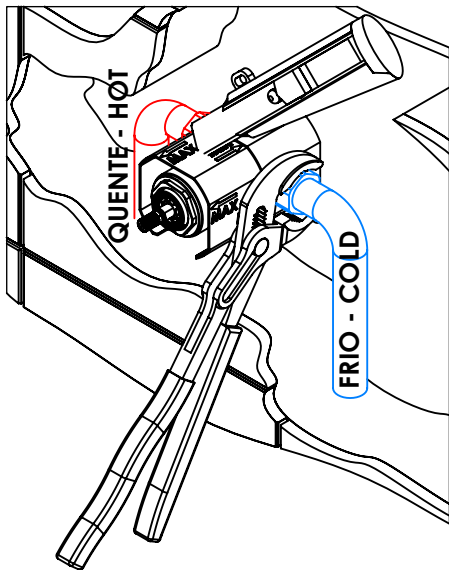

2 FIXED

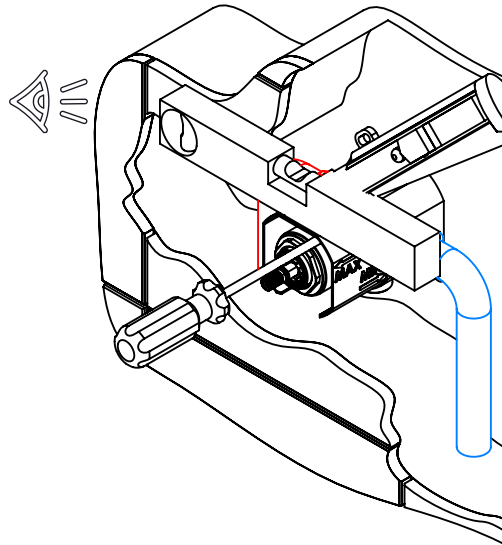

3 REMOVE PROTECTION

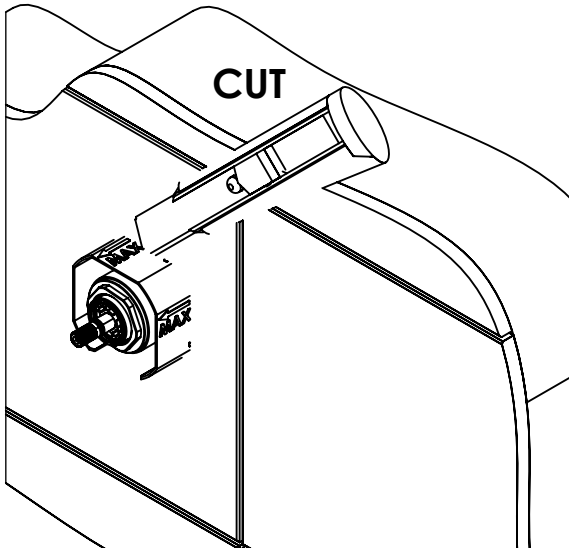

4 FIX IT

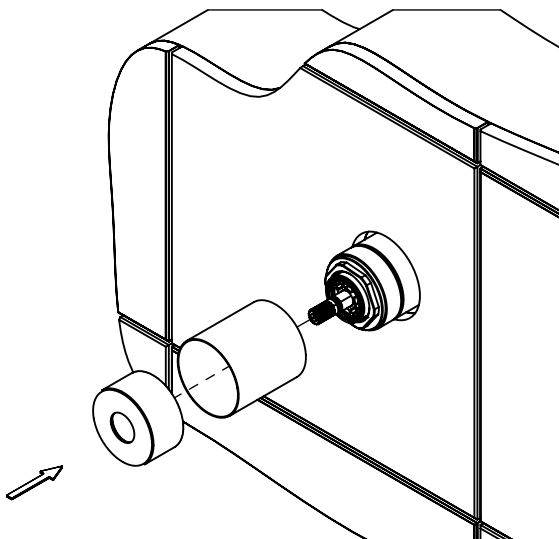

5 FIX IT

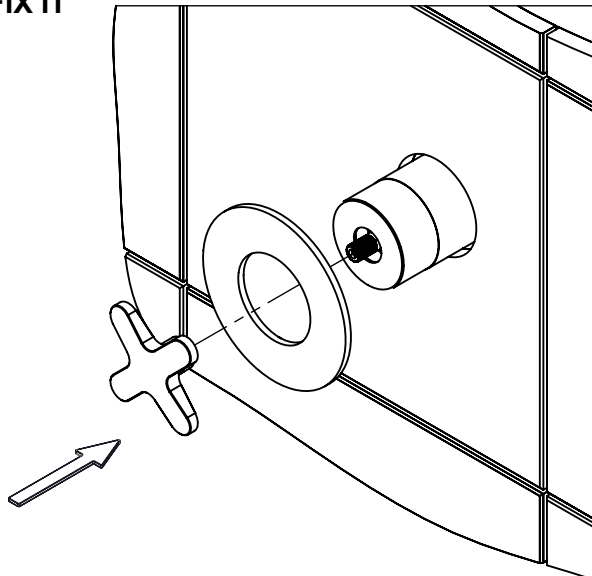

6 MAINTENANCE

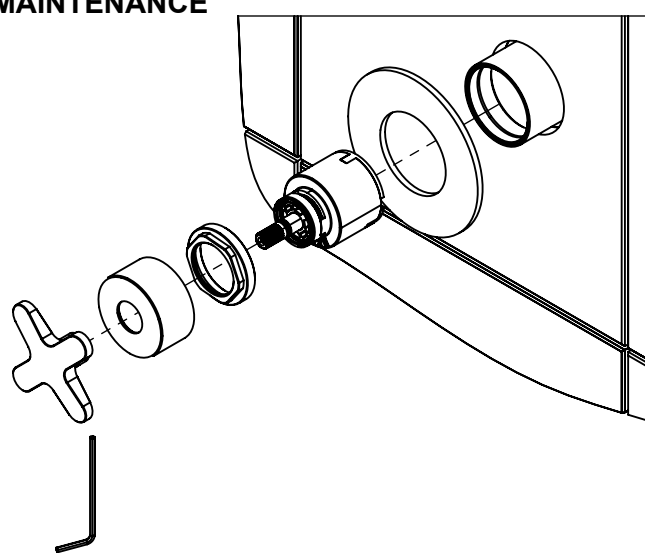

24/02/2026
Rev.
CROSS090