



CZ020

MISTURADORA BIDE CRUZETA

EN BIDET MIXER CRUZETA

FR MÉLANGEUR BIDE CRUZETA

ES MEZCLADOR BIDÉ CRUZETA



A S M T A P S

W A T E R S O U L

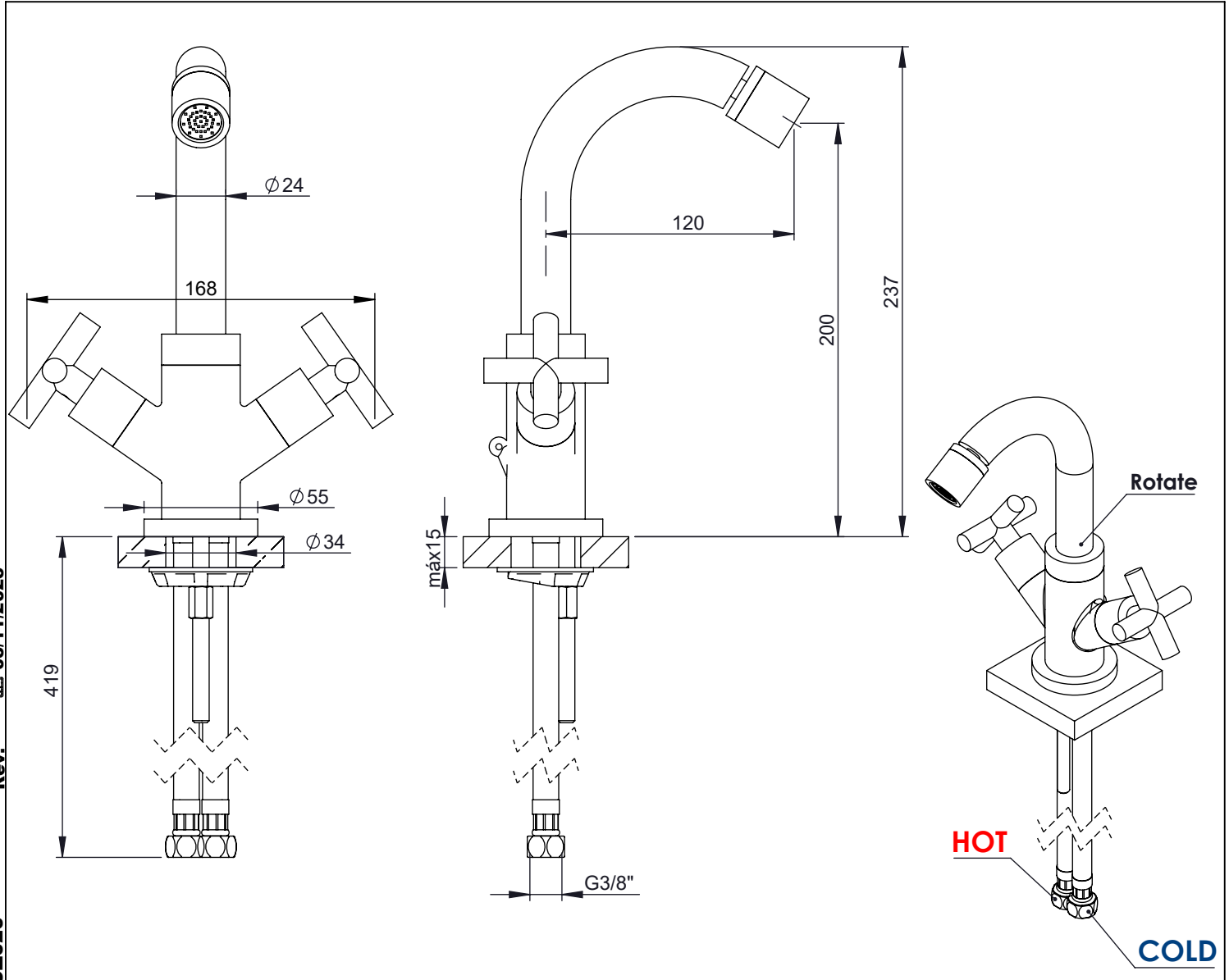

CZ020 Rev. 03/11/2025

CARACTERÍSTICAS TÉCNICAS

PRESSÃO RECOMENDADA:
RECOMMENDED PRESSURE: 3 - 4 BAR

TEMPERATURA RECOMENDADA:
RECOMMENDED TEMPERATURE: 15°C - 65°C

MATERIAIS:
MATERIALS: Latão

TEMPERATURA MÁXIMA:
MAXIMUM TEMPERATURE: 70°C

CAUDAL MÁXIMO A 3 BAR:
MAXIMUM FLOW AT 3 BAR: L/MIN

LIGAÇÃO DE ENTRADA:
INPUT CONNECTION: G1/2"

LIGAÇÃO DE SÉIDA:
OUTPUT CONNECTION: G1/2"

PESO (KG):
WEIGHT (KG): 1,49

DIMENSÕES EMBALAGEM (MM):
SIZE PACKAGING (MM): 365x250x80

ACABAMENTOS

CR - CROMADO | CHROME | CHROME | CROMO

PR - PRETO MATE | BLACK MATT | NOIR MAT | NEGRO MATE

BR - BRANCO MATE | WHITE MATT | BLANC MAT | BLANCO MATE

ST - SATINOX | SATINOX | SATINOX | SATINOX

AT - ANTRACITE | ANTHRACITE | ANTHRACITE | ANTRACITA

GM - GUNMETAL | GUNMETAL | GUNMETAL | GUNMETAL

GMM - GUNMETAL MATE | GUNMETAL MATT | GUNMETAL MAT | GUNMETAL MATE

OR - DOURADO | GOLD | DORÉ | DORADO

ORM - DOURADO MATE | GOLD MATT | DORÉ MAT | DORADO MATE

CB - COBRE | COPPER | CUIVRE | COBRE

CBM - COBRE MAT | COPPER MAT | CUIVRE MAT | COBRE MATE

TECNOLOGIA

 AC1360 - CASTELO CERÂMICO 1/2" 1/4 VOLTA
AC1360 - CERAMIC VALVE 1/2" 1/4 TURN