

SLIMASM090

MONOCOMANDO EMBUTIR DUCHE 1 VIA
SLIMASM



ASM TAPS®

WATER SOUL

EN CONCEALED 1 WAY OUT SHOWER MIXER
SLIMASM

FR MITIGEUR DOUCHE ENCASTRÉE 1 VOIE
SLIMASM

ES MONOMANDO DUCHA EMPOTRAR 1 VIA
SLIMASM

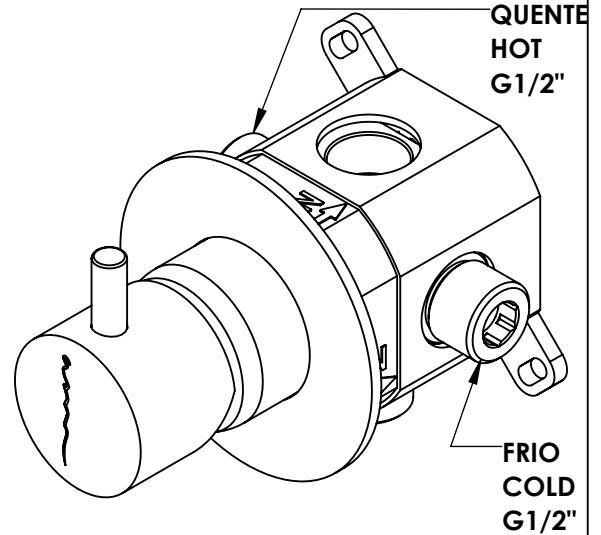
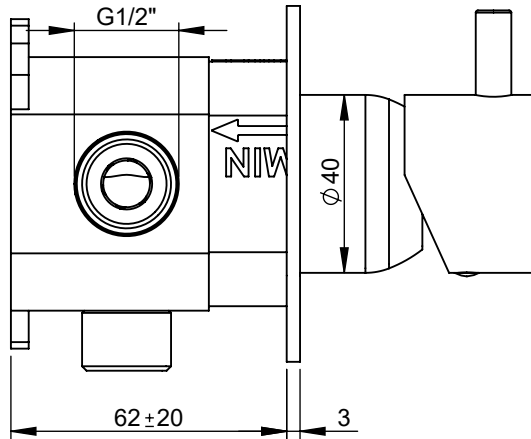
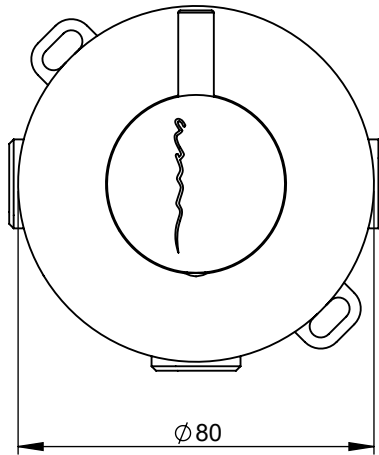

SLIMASM090 Rev.A 25/02/2026

CARACTERÍSTICAS TÉCNICAS

PRESSÃO RECOMENDADA:
RECOMMENDED PRESSURE: 3 - 4 BAR

TEMPERATURA RECOMENDADA:
RECOMMENDED TEMPERATURE: 15°C - 65°C

MATERIAIS:
MATERIALS: Latão

TEMPERATURA MÁXIMA:
MAXIMUM TEMPERATURE: 70°C

CAUDAL MÁXIMO A 3 BAR:
MAXIMUM FLOW AT 3 BAR: L/MIN

LIGAÇÃO DE ENTRADA:
INPUT CONNECTION: G1/2"

LIGAÇÃO DE SÁIDA:
OUTPUT CONNECTION: G1/2"

PESO (KG):
WEIGHT (KG): 1,75

DIMENSÕES EMBALAGEM (MM):
SIZE PACKAGING (MM): 250x90x100

ACABAMENTOS

CR - CROMADO | CHROME | CHROME | CROMO

PR - PRETO MATE | BLACK MATT | NOIR MAT | NEGRO MATE

BR - BRANCO MATE | WHITE MATT | BLANC MAT | BLANCO MATE

ST - SATINOX | SATINOX | SATINOX | SATINOX

AT - ANTRACITE | ANTHRACITE | ANTHRACITE | ANTRACITA

GM - GUNMETAL | GUNMETAL | GUNMETAL | GUNMETAL

GMM - GUNMETAL MATE | GUNMETAL MATT | GUNMETAL MAT | GUNMETAL MATE

OR - DOURADO | GOLD | DORÉ | DORADO

ORM - DOURADO MATE | GOLD MATT | DORÉ MAT | DORADO MATE

CB - COBRE | COPPER | CUIVRE | COBRE

CBM - COBRE MAT | COPPER MAT | CUIVRE MAT | COBRE MATE

TECNOLOGIA

AC540A - Cartucho Ø35
AC540A - Cartridge Ø35

Embutido a parede
Built-in to wall

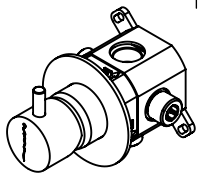

SLIMASM090

MONOCOMANDO EMBUTIR DUCHE 1
VIA SLIMASM



ASM TAPS®

WATER SOUL

LISTA DE COMPONENTES

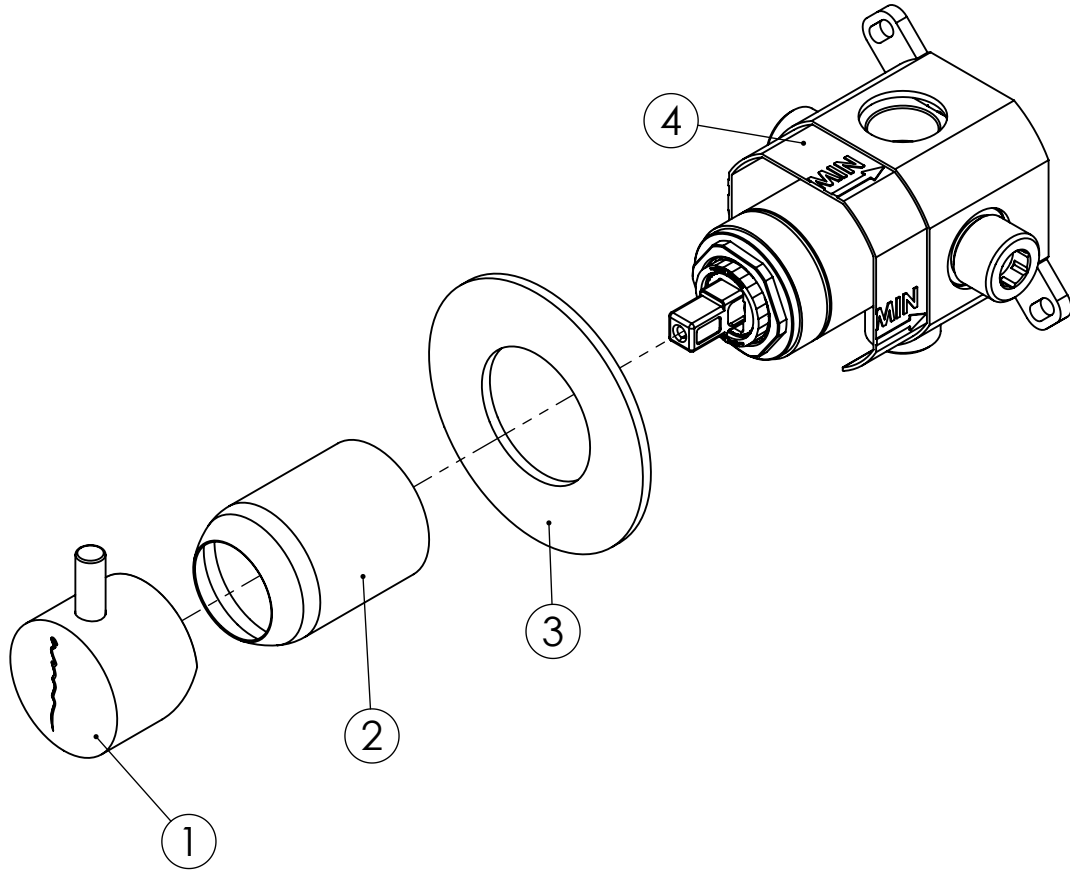

SLIMASM090 Rev.A 25/02/2026

Nº	DESCRIPTION	REF.	QT.
1	MANÍPULO C/PERNO EMBUTIDOS CILÍNDRICO	AC1110	1
2	COPO EMBUTIDOS EXTERIOR	101557	1
3	ESPELHO 1 VIA CILÍNDRICO	100274	1
4	BOX MONOC. EMBUTIR LAVATÓRIO SEPARADO / DUCHE 1 VIA	INT102	1

! SERVICE



SLIMASM090

MONOCOMANDO EMBUTIR DUCHE 1 VIA SLIMASM



A S M T A P S[®]

W A T E R S O U L

INSTALLATION MANUAL

1 CONECTION

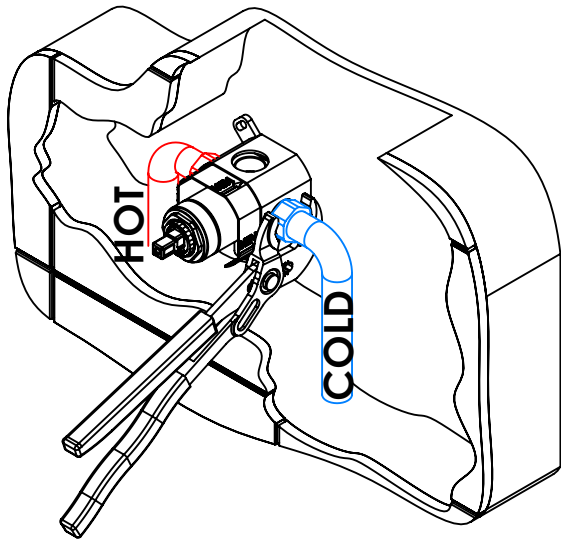

2 FIXED

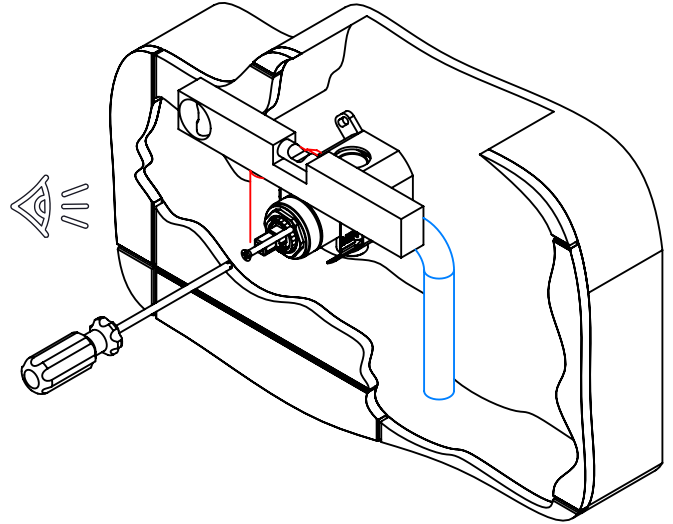

3 CUT THE PROTECTION

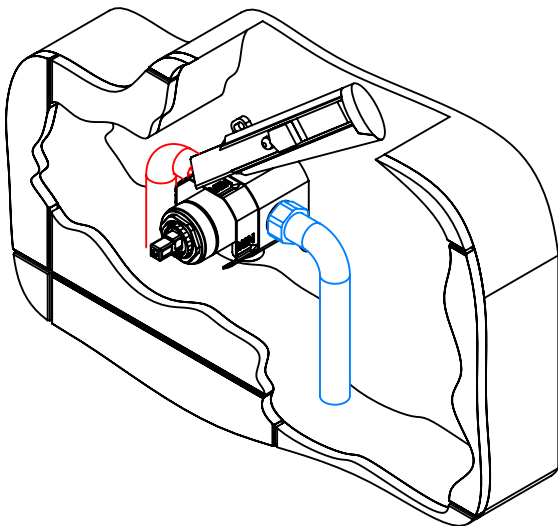

4 FIX IT

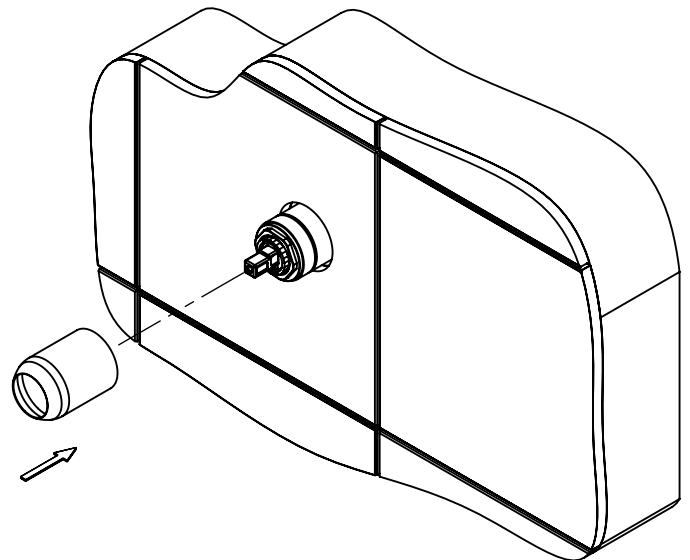

5 FIX IT

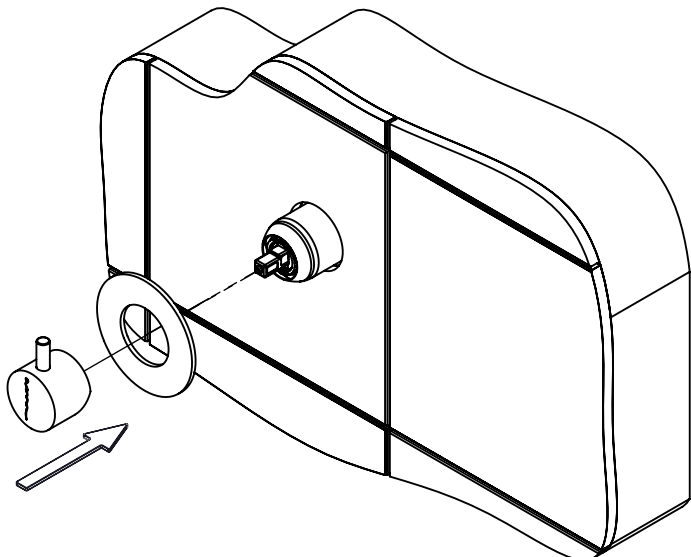

6 MAINTENANCE

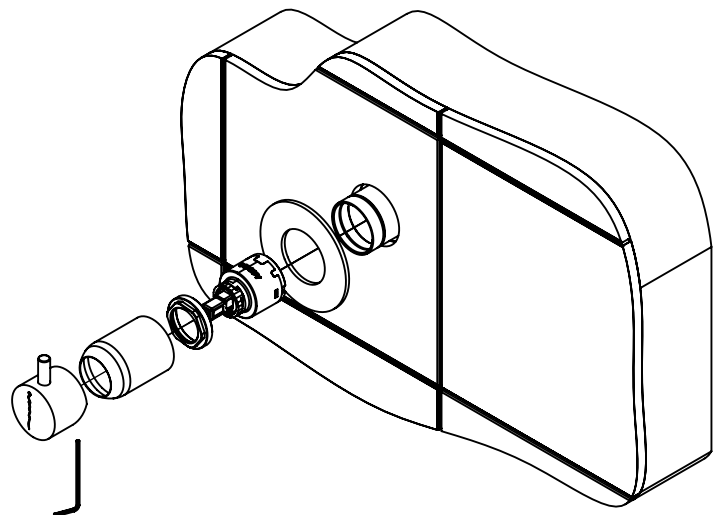

SLIMASM090 Rev.A 25/02/2026