



# TERCLUX080

MISTURADORA EMBUTIR TERMOSTÁTICA 2 VIAS LUX



ASM TAPS®

WATER SOUL

**EN** CONCEALED 2 WAYS THERMOSTATIC MIXER LUX

**FR** MÉLANGEUR ENCASTRÉ 2 VOIES THERMOSTATIQUE LUX

**ES** MÉLANGEUR ENCASTRÉ 2 VOIES THERMOSTATIQUE LUX

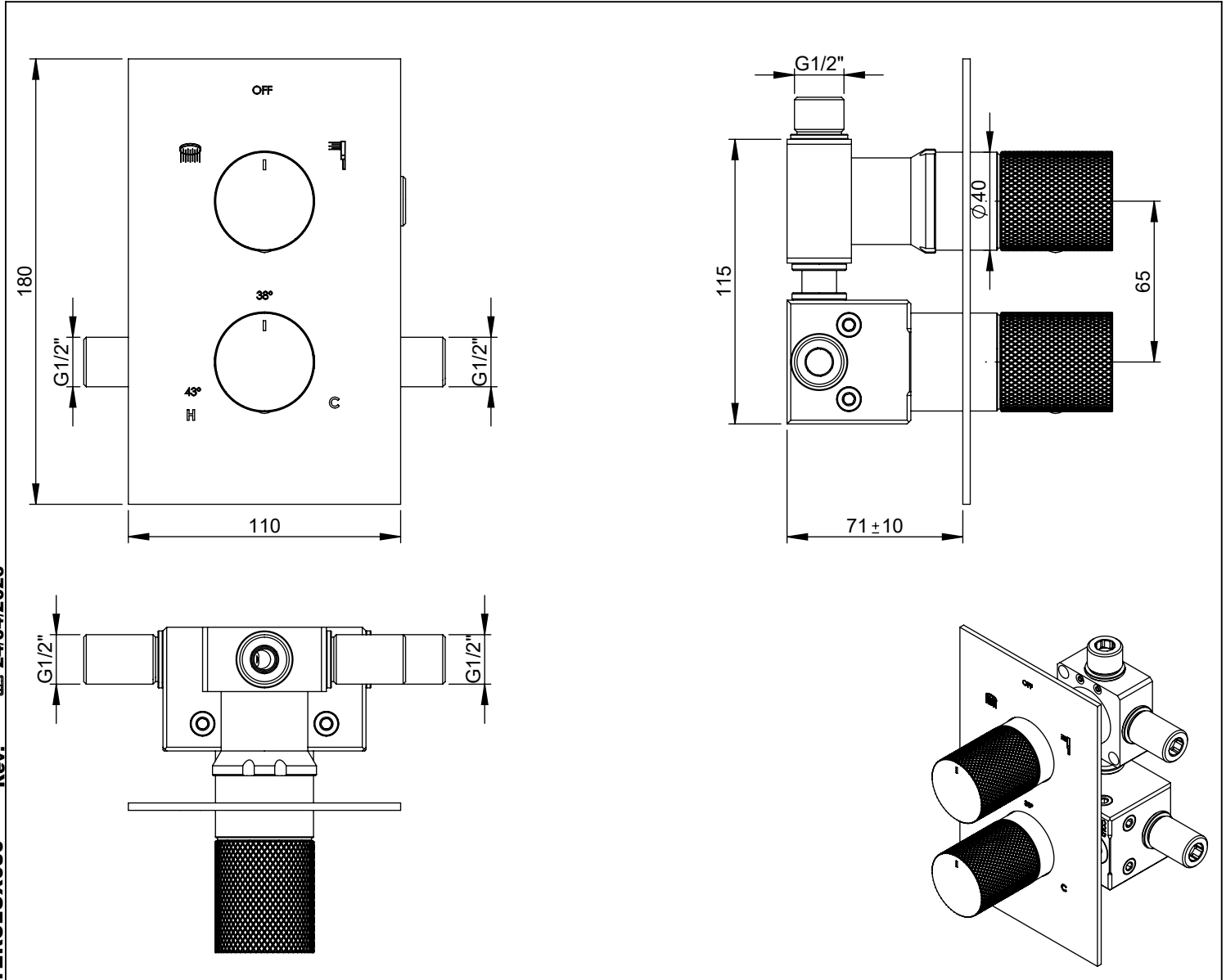

Rev. 24/04/2026

TERCLUX080





## CARACTERÍSTICAS TÉCNICAS

PRESSÃO RECOMENDADA: RECOMMENDED PRESSURE:	3 - 4 BAR
TEMPERATURA RECOMENDADA: RECOMMENDED TEMPERATURE:	15°C - 65°C
MATERIAIS: MATERIALS:	Latão
TEMPERATURA MÁXIMA: MAXIMUM TEMPERATURE:	70°C
CAUDAL MÁXIMO A 3 BAR: MAXIMUM FLOW AT 3 BAR:	L/MIN
LIGAÇÃO DE ENTRADA: INPUT CONNECTION:	G1/2"
LIGAÇÃO DE SÉIDA: OUTPUT CONNECTION:	G1/2"
PESO (KG): WEIGHT (KG):	3,205
DIMENSÕES EMBALAGEM (MM): SIZE PACKAGING (MM):	285x200x170

## ACABAMENTOS

CR - CROMADO   CHROME   CHROME   CROMO
PR - PRETO MATE   BLACK MATT   NOIR MAT   NEGRO MATE
BR - BRANCO MATE   WHITE MATT   BLANC MAT   BLANCO MATE
ST - SATINOX   SATINOX   SATINOX   SATINOX
AT - ANTRACITE   ANTHRACITE   ANTHRACITE   ANTRACITA
GM - GUNMETAL   GUNMETAL   GUNMETAL   GUNMETAL
GMM - GUNMETAL MATE   GUNMETAL MATT   GUNMETAL MAT   GUNMETAL MATE
OR - DOURADO   GOLD   DORÉ   DORADO
ORM - DOURADO MATE   GOLD MATT   DORÉ MAT   DORADO MATE
CB - COBRE   COPPER   CUIVRE   COBRE
CBM - COBRE MAT   COPPER MAT   CUIVRE MAT   COBRE MATE

## TECNOLOGIA

-  AC1180-Distribuidor Misturadora Termostática  
AC1180-Distributor Thermostatic Mixer
-  AC1940 - Cartucho termostático Mini Kerox  
AC1940 - Mini Thermostatic Cartridge Kerox
-  Embutido a parede  
Built-in to wall
-  Termostática  
Thermostatic

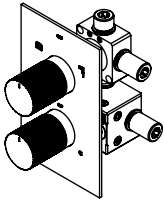

# TERCLUX080

MISTURADORA EMBUTIR  
TERMOSTÁTICA 2 VIAS LUX



ASM TAPS®

WATER SOUL

## LISTA DE COMPONENTES

TERCLUX080 Rev. 24/04/2026

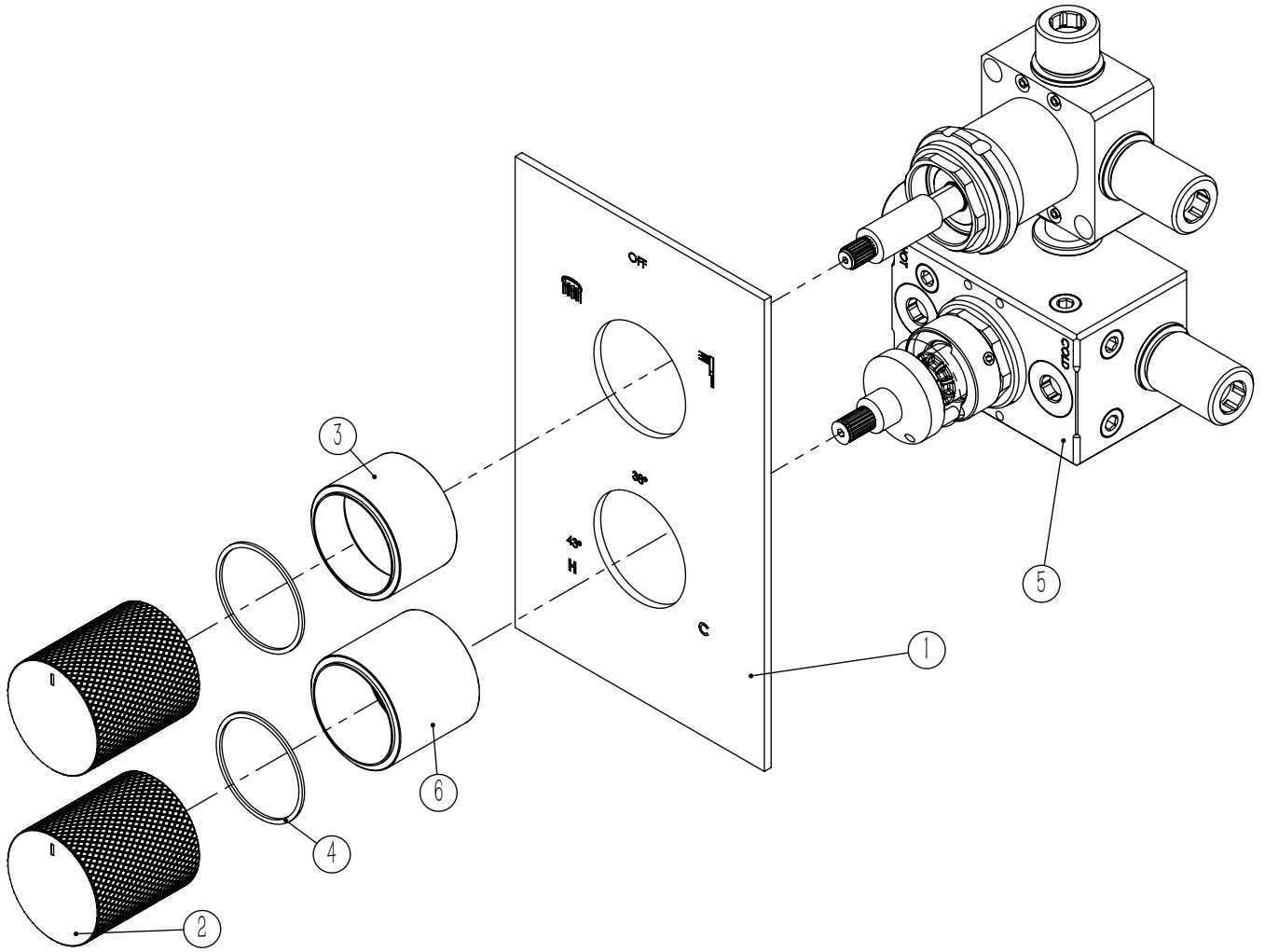

Nº	DESCRIPTION	REF.	QT.
1	Espelho TERC080 Vertical	100671	1
2	MANÍPULO DISTRIBUIDOR LUX	AC2090	2
3	Campânula Cartucho Mist. Embutir Termostática 2 Vias	100636	1
4	Anilho Nylon Ø35x38x1	T112378	2
5	BOX MISTURADORA EMBUTIR TERMOSTÁTICA 2 VIAS	INT114	1
6	CAMPANULA 35 TERMOSTÁTICA 2 VIAS	101515	1

# ! SERVICE

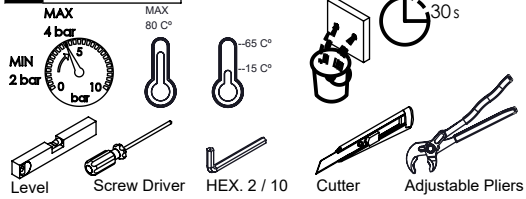

# TERCLUX080

## MISTURADORA EMBUTIR TERMOSTÁTICA 2 VIAS LUX



A S M T A P S ®

W A T E R S O U L

### INSTALLATION MANUAL

#### 1 CONECTION

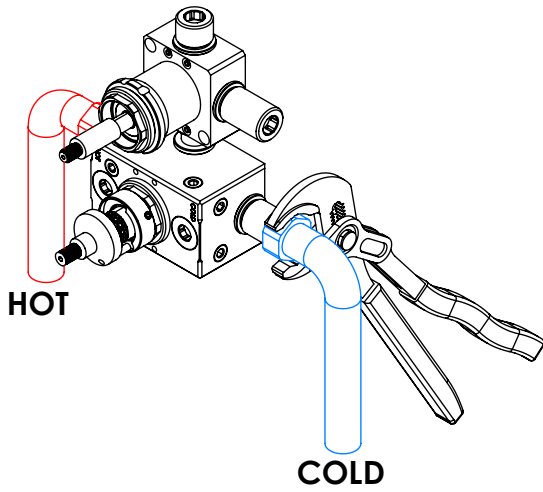

#### 2 FIXED

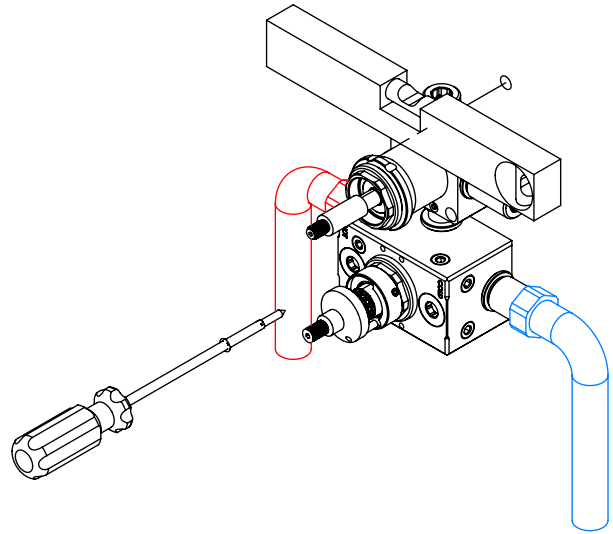

#### 3 FIX IT

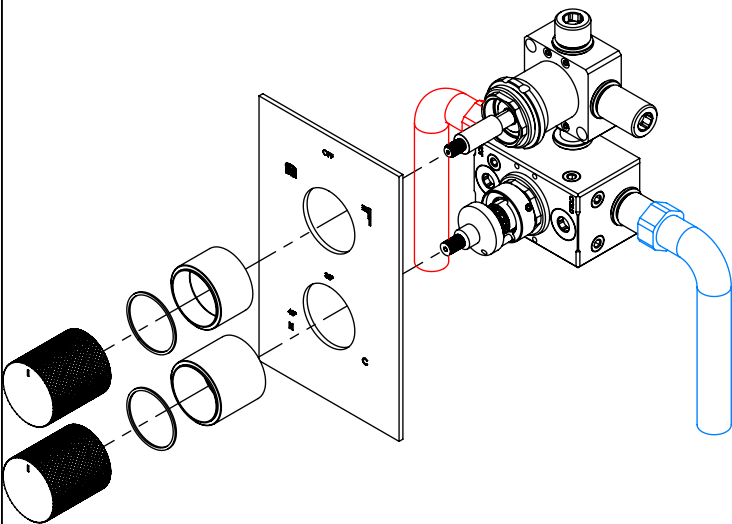

#### 4 MAINTENANCE

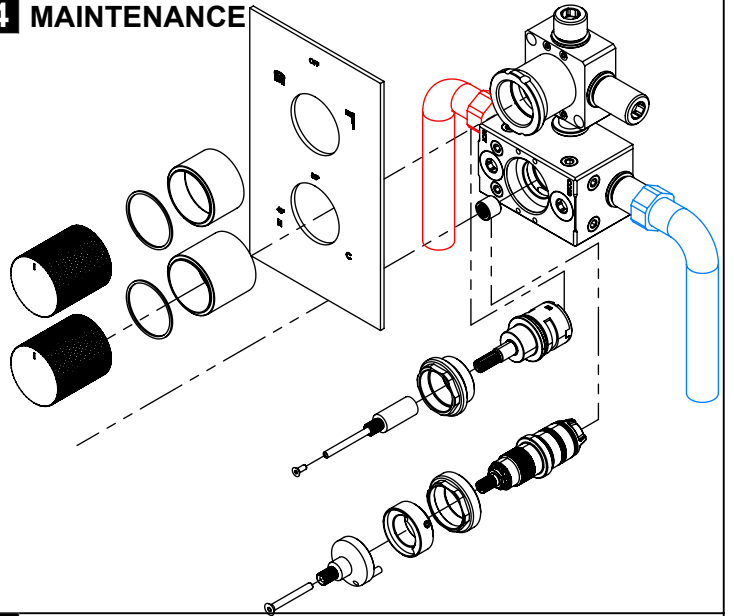

#### 5

#### 6

24/04/2026

Rev.

TERCLUX080